

PARTIAL DISCHARGE (PD) TESTING OF M.V / H.V INSTRUMENT TRANSFORMER

PD testing of Instrument Transformers:

Partial Discharges (PD) in the high voltage insulation are local breakdowns of the insulation which does not result in a complete failure of insulation. Hence, the discharges are called partial. The change in the PD value is measured in unit apparent charge pC.

Current transformers and Potential transformer are very important equipments of any power system for metering and protection. Failure of these equipments will cause

- Short circuit fault in the system,
- Damage to other surrounding equipment / switchgear and
- Cause Non-availability of the system.

Reasons for PD in Instrument Transformers:

The instrument transformers when manufactured in factory, due to its manufacturing process workmanship, some voids are present. These voids over a period of time start increasing in size due to overvoltages in system or ageing. When a voltage is applied to the object the gaseous particles start getting ionizing. At a particular stage the void size increases causing the apparent charge (pC) value to increase and finally cause failure of the instrument transformer. The failure or increase in PD value can also be due to moisture or contamination on the external surface of the equipment which may cause tracking with respect to earth.

Test Description and Set up:

For this test rated phase to neutral voltage is applied across the object. A coupling capacitor (having low inductance) is connected across the test object which converts the input currents to low output voltage. The output of this coupling capacitor is fed to the PD measuring instrument which gives the PD value in Pico Coulomb and also indicates the discharges on the sinusoidal waveform. The most important requirement for this test is a PD free power source transformer. The circuit for PD testing is shown in Fig. 1 below

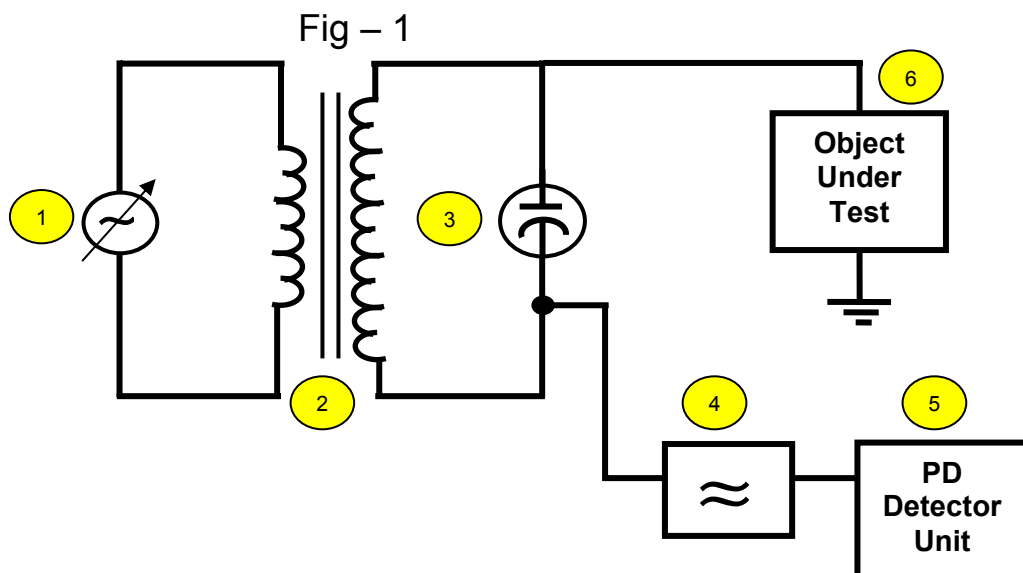

- 1 Variable 230V 50 Hz supply
- 2 0-50kV, 40mA AC Power Source
- 3 50kV, 330pF Coupling Capacitor
- 4 Integrator Filter Circuit
- 5 XDPIIB PD detector unit
- 6 Object under test

Limiting values and Testing schedule:

As per Indian Standard (IS) 11322 – the limiting value of PD in Cast resin instrument transformer is < 50 pC

Manufacturers limit this value to less than 20 pC before dispatch from their factory.

PD testing of instrument transformers should be carried out

- Just before commissioning to have the base foot print values at site.
- Once in every 2 years to trend the ageing or increase in the pC value and
- Depending upon the pC value measured over a period of six or twelve months.

Test Equipment and Experience:

Power – Linker group is already working for condition monitoring and diagnostic analysis of Generators, Transformers, Motors, Lightning Arrestors, cables etc. The equipment of “Partial Discharge measurement in Instrument Transformer” is XDPIIB from ndb Technologies Inc. Canada. For detailed description of this test instrument you may view at: <http://www.ndbtech.com/en/partial-discharge-detection.php>

You may write to us for any of your requirement of PD testing of instrument transformer. For other Condition monitoring and diagnostic tests, which are carried out by POWER – LINKER, you may view at : www.powerlinker.org/htm/cndmdt.htm

We now look forward to receiving your enquiry, if any for Partial Discharge measurement of instrument transformers.